

RELAIS LAVABO RE100.BI

GLOBO



Cod. RE100.BI

Lavabo 100 cm a foro predisposto a tre fori diaframmati. Con foro troppo pieno.
Installazione sospesa, su colonna o per mobile. Completo di fissaggi. Peso 29 kg.
Basin 100cm one hole, arranged for three tap holes. Provided with overflow hole.
Wall-hung, installation on pedestal or on piece of furniture. Fixing kit included. Weight 29 kg.

Cod. PL100CR

Portasciugamani in ottone cromato. Peso 1,9 kg.
Brass chromium-plated towel rail. Weight 1,9 kg.

Cod. PL100OR

Portasciugamani in ottone dorato. Peso 1,9 kg.
Brass golden towel rail. Weight 1,9 kg.

• Punto di ancoraggio per accessori ø 16 mm
Fixing point for accessories ø 16mm

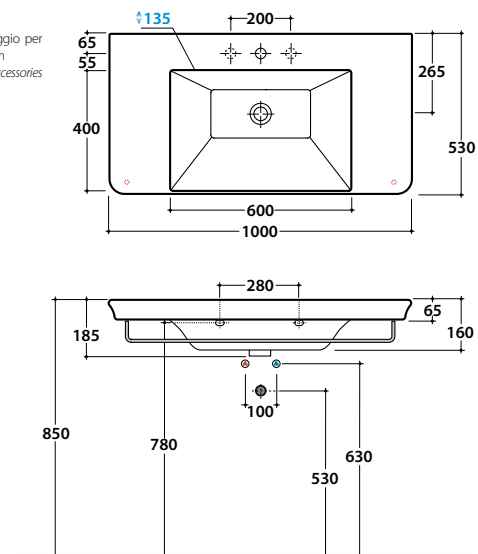

Cod. RE005.BI

Colonna a terra. Peso 12 kg.
Floor mounted pedestal. Weight 12 kg.

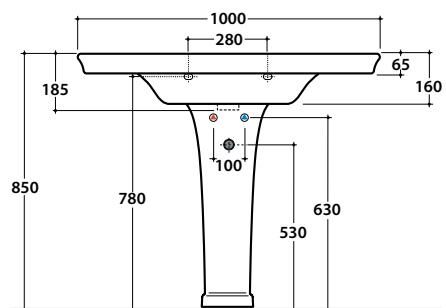

Cod. RES05.BI

Colonna sospesa. Peso 10 kg.
Wall-hung pedestal. Weight 10 kg.

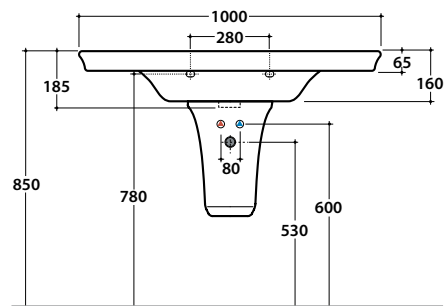

RELAIS LAVABO RE100.BI

GLOBO



Mobile sospeso 100 in m.d.f. laccato per lavabo cod. RE100 BI - RE100 NE, provvisto di due cassetti. Peso 46 kg.

Wall-hung varnished m.d.f. cabinet 100cm to be matched with basins cod. RE100 BI - RE100 NE, provided with two drawers. Weight 46 kg.

 Cod. **MS100BC** Bianco-cromo / *White-chrome*

 Cod. **MS100NC** Nero-cromo / *Black-chrome*

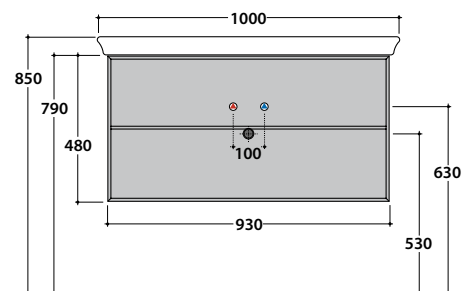

Apertura massima cassetti cm. 84,5
Drawers full-opening 84,5cm



Mobile a terra 100 in m.d.f. laccato per lavabo cod. RE100 BI - RE100 NE, provvisto di due cassetti. Peso 59 kg.

Floor-mounted varnished m.d.f. cabinet 100cm to be matched with basins cod. RE100 BI - RE100 NE, provided with two drawers. Weight 59 kg.

 Cod. **MT1001X** Bianco-cromo / *White-chrome*

 Cod. **MT1003X** Nero-cromo / *Black-chrome*

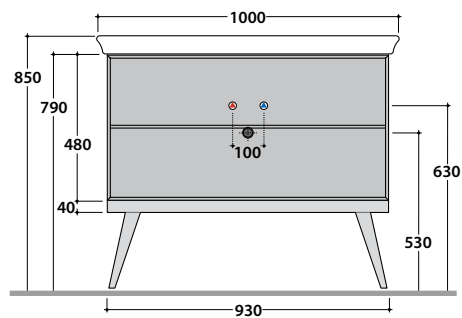

Apertura massima cassetti cm. 84,5
Drawers full-opening 84,5cm

RELAIS LAVABO RE100.BI

GLOBO

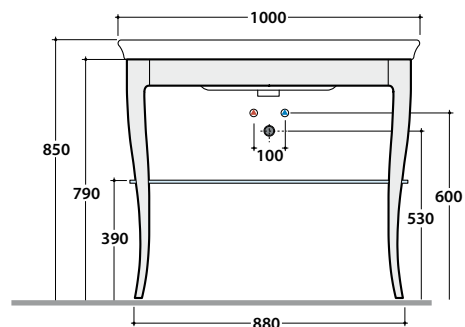

Struttura portalavabo 100 in metallo a terra. Peso 15 kg.
Floor mounted metal structure for basin 100cm. Weight 15 kg.

 Cod. **ST100BI** Bianco lucido / *Shiny white*

 Cod. **ST100NE** Nero lucido / *Shiny black*

 Cod. **ST100CR** Cromo / *Chrome*

Cod. **RI100VE**

Ripiano in vetro temperato extrachiaro. Peso 7,4 kg.
Extra-bright tempered glass counter top. Weight 7,4 kg.

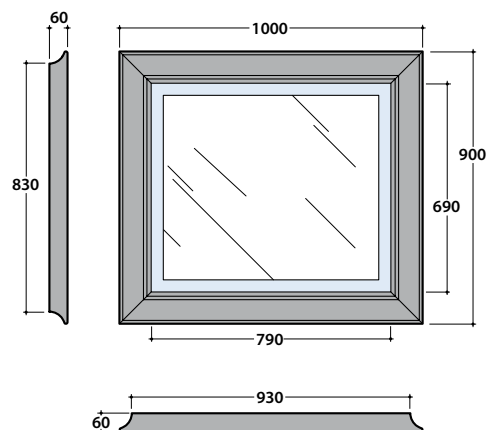

Specchiera retroilluminata cm 100 con cornice in legno massello laccato.
Non reversibile. Peso 16 kg.
Backlit mirror 100cm with varnished solid wood frame. Not Reversible. Weight 16 kg.

 Cod. **SP100BI** Bianco lucido / *Shiny white*

 Cod. **SP100NE** Nero lucido / *Shiny black*

 Cod. **SP100AG** Foglia argento / *Silver-leaf*